

Für dieses Dokument behalten wir uns alle Rechte vor.
 Nous nous réservons tous les droits sur ce document.
 We reserve all rights in connection with this document.

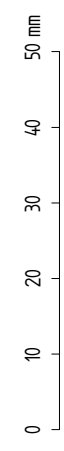

The inner contour does not correspond to the standard ISO 26623-1

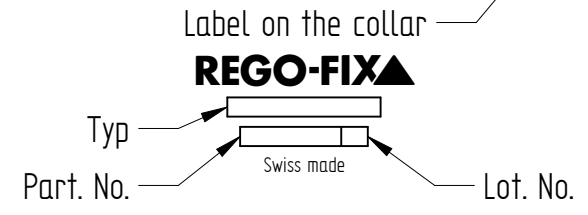
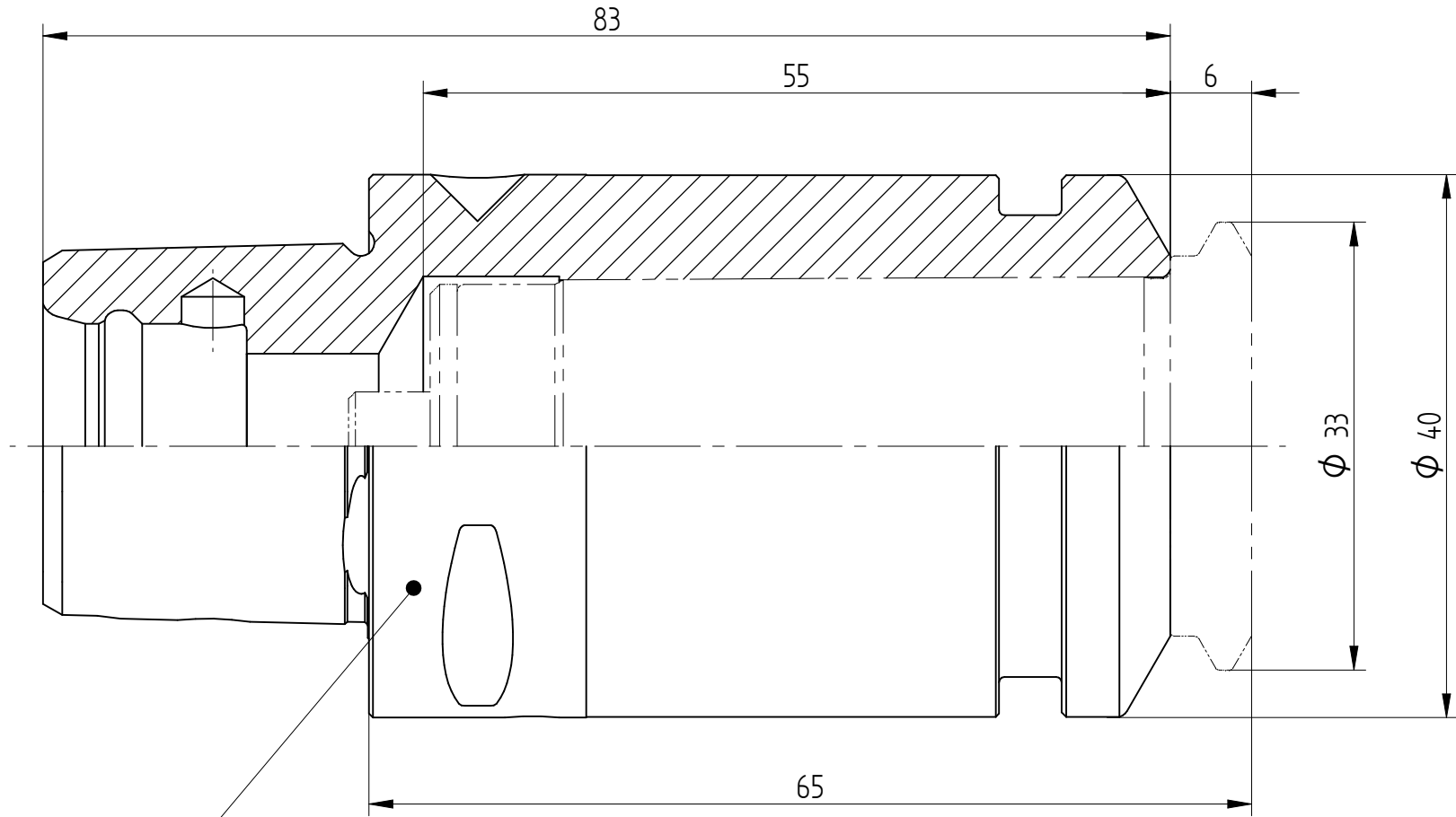

Nicht zu verwenden mit Typ PG-L Spannzangen für lange Werkzeugschäfte.
 Not for use with PG-L type collets for long toolshanks.

Acceptance

Company name: Person:

Date: Signature:

B Anpassung an RF-Standard / ohne ZA		15.10.2020		FSI			
Mod	Änderung			Datum	Name		
Gewicht: 0.40 kg			Format	Masstab	gezeichnet	02.03.2017	sfurer
Massblatt			A3	2:1	geprüft	15.10.2020	sdettwiler
					freigegeben	15.10.2020	mbroennimann
		Blatt / Anz.		0018414		B	
		1 / 1		C4_PG25x065-M			