

reCool®

*The first of its kind system
to convert your existing
live tooling to thru coolant*

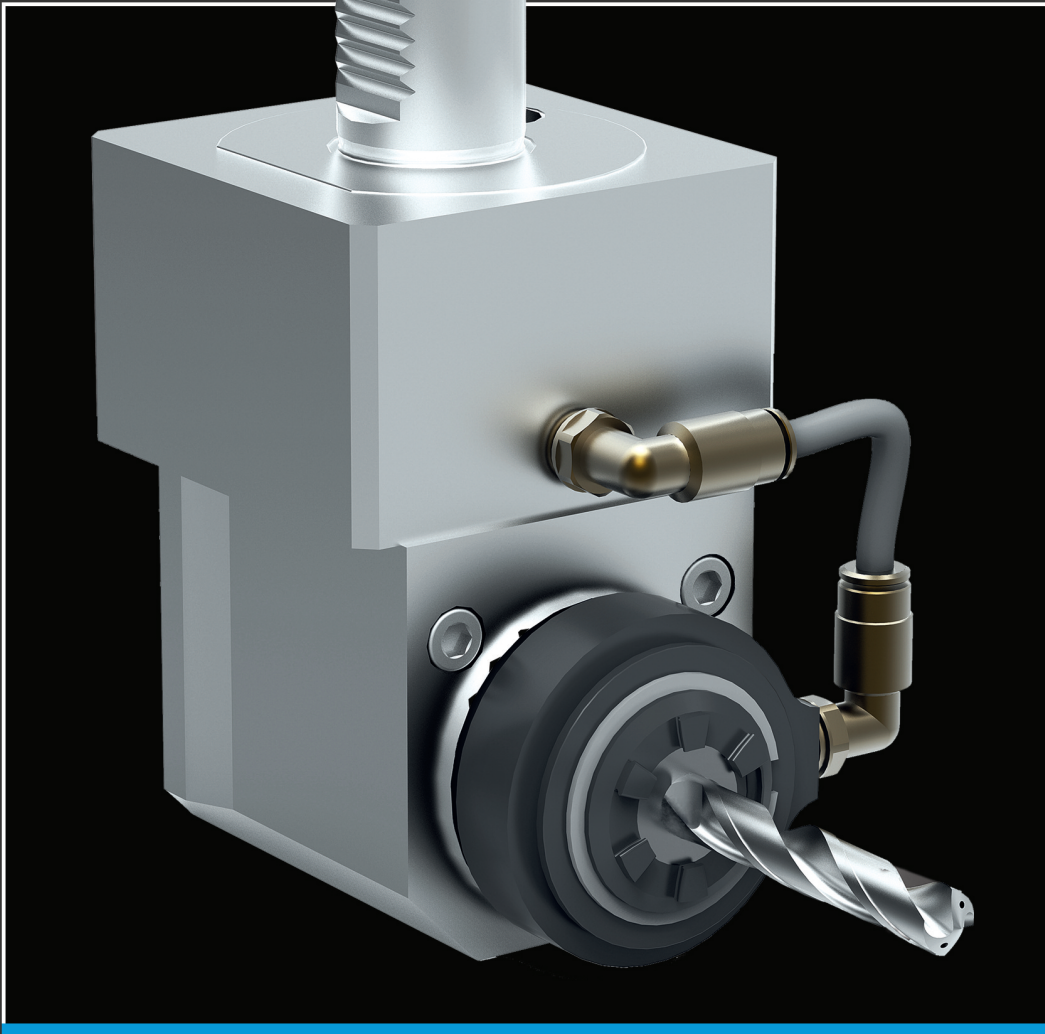

reCool® Rotary Coolant Supply System

- Converts existing tooling systems to thru coolant at low costs in 2 minutes
- For using ER-collets in driven tools with metric external thread (ISO 15488/DIN 6944)
- Speeds up to **12,000 rpm***
- Coolant pressures up to **70 bar/1,000 PSI***
- Maintenance-free coolant lubricated bearings
- For coolant-thru tools (with DS sealing discs) and for peripheral cooling (with KS flush discs)

** Exact pressure maximum dependent upon application, ER series, and pressure loss in system. Tubing might need to be upgrade for higher pressures. ER 40 reCool units max of 6,000 rpm.*

www.rego-fix.com
800.999.7346
info@reg-fix.com

Made in
Switzerland



Swiss
Precision
Tools



REGO-FIX®

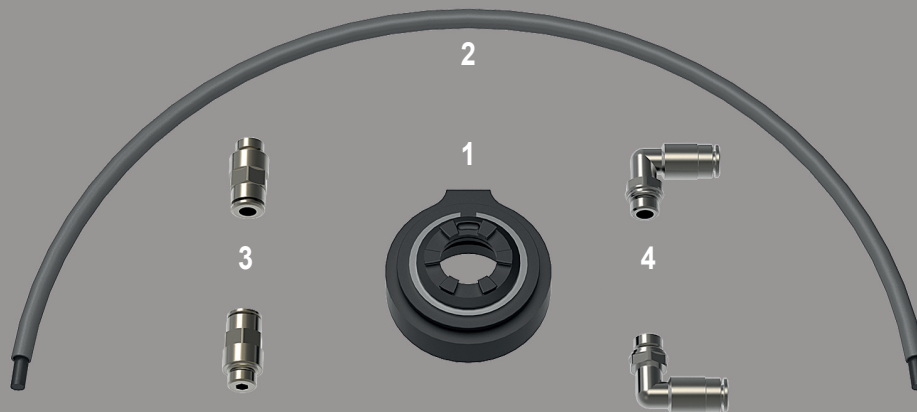

Benefits of Internal Cooling with reCool

- Optimized coolant for all tools and for difficult to access machining
- Suitable for use with the REGO-FIX Coolant disk or Coolant flush systems
- More coolant reaches the cutting tool without splattering or spray losses
- Tool lubrication is optimized via through tool coolant
- Increased chip removal

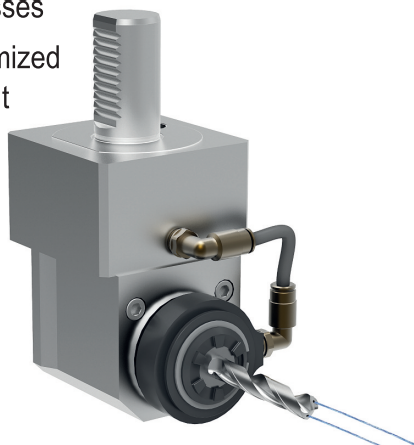

reCool Coolant Supply set includes:

- 1 reCool clamping nut with outer ring
- 2 Coolant pipe with protector (0.6mm, 400 mm length)
- 3 1/8" BSP straight push-in fitting
- 4 1/8" BSP elbow push-in fitting

Type	Part No.
RCR/ER 16	3716.00000
RCR/ER 20	3720.00000
RCR/ER 25	3725.00000
RCR/ER 32	3732.00000
RCR/ER 40	3740.00000

Notes:

- 1) Designed for water-based coolant systems not oil-based
- 2) Collets, disks & wrenches not included

Peripheral cooling without reCool

- Adjustment and control of the nozzles or spray tubes with different tool length and tool diameter is limited
- Coolant may not be direct at the cutting edge resulting in higher wear on the cutting tool
- Splattering losses of the spray jet
- Poor chip removal



Watch reCool in action



REGO-FIX TOOL CORPORATION

7752 Moller Road
Indianapolis, IN 46268 USA

Toll Free: 800.999.7346

Phone: 317.870.5959

Fax: 317.870.5955

Email: info@rego-fix.com

www.rego-fix.com